

OPERATION AND MAINTENANCE MANUAL

操作和维护手册

DOUBLE SUCTION SPLIT CASE PUMPS

卧式双吸水平中开泵

Patterson Pump Company

A Gorman-Rupp Company

PO Box 790
2129 Ayersville Road
Toccoa, Georgia 30577
Telephone: 706.886.2101

SAFETY PRECAUTIONS 安全预防措施

WARNING 警告

Do not operate this equipment in excess of its rated speed or other than in accordance with the instructions contained in this manual.

禁止设备在超过其额定转速或包含在本手册的其他说明条件下运行。

The equipment has been found satisfactory of the conditions for which it was sold, but its operation in excess of these conditions may subject it to stresses and strains which it was not designed to withstand.

设备销售出厂时已经符合并达到可运行的条件。如在非正常工况下运行设备，设备可能面临非设计条件允许的破坏。

For equipment covered by this instruction book, it is important to observe safety precautions to protect personnel from possible injury. Among the many considerations, personnel should be instructed to:

该手册重要的部分是要遵循列出的安全措施，以保护操作人员避免受到可能的伤害。另外需要特别注意以下事项：

- avoid contact with rotating parts 禁止接触旋转部件
- avoid bypassing or rendering inoperative any safeguards or protective devices
禁止不顾或取消任何安全措施或保护装置。
- avoid extended exposure in close proximity to machinery with high noise levels
由于高噪音，禁止长时间暴露于靠近设备的位置。
- use proper care and procedures in handling, lifting, installing, operating and maintaining the equipment
对设备需进行正确的操作、吊装、安装、操作和维护。
- do not modify this equipment – consult factory if modification is deemed necessary
不得改装或调整设备的出厂配置。如需必要的修改，调整或改装等请咨询工厂。
- do not substitute for repair parts which can be provided by the equipment manufacturer.
不得使用其他设备制造商提供的配件。

Safe maintenance practices with qualified personnel are imperative.

设备必须由经过培训并合格的人员进行维护或操作。

Failure to heed this warning may result in an accident causing personal injury.

不注意这个警告可能导致意外事故，造成人身伤害。

TABLE OF CONTENTS 目录

SECTION I 第一部分 GENERAL INFORMATION 基本信息	4
SECTION II 第二部分 STORAGE & PROTECTION 储存和保护	5
SECTION III 第三部分 INSTALLATION 安装	6
3-1 Location: 位置.....	6
3-2 Foundation: 基础.....	6
3-3 Mounting: 就位.....	6
3-4 Alignment: 校准对中.....	7
3-5 Grouting: 二次灌浆.....	11
3-6 Piping: 管道连接.....	11
SECTION IV 第四部分 OPERATION 操作	14
4-1 Starting: 启动.....	14
4-2 Shutdown 停机.....	15
4-3 Minimum Flow Limitation 最小流量的限制.....	15
SECTION V 第五部分 MAINTENANCE 维护	17
5-1 Lubrication: 润滑.....	17
5-2 Stuffing Box: 填料函.....	18
5-3 Wear Ring Clearance: 承磨环间隙.....	20
SECTION VI 第六部分 REPAIRS AND REPLACEMENT 泵维修和配件更换	25
6-1 To Remove Rotor: 拆卸泵壳.....	25
6-2 Disassembly of Rotating Element: 泵旋转组件的拆卸.....	26
6-3 To Remove Impeller Rings: 拆卸叶轮承磨环.....	27
6-4 Inspection: 检查.....	27
6-5 Assembly: 组装.....	31
LOCATING OPERATING DIFFICULTIES 操作难点	32
RECOMMENDED SPARE PARTS FOR DOUBLE SUCTION PUMPS 双吸泵推荐的备件	35

SECTION I 第一部分 GENERAL INFORMATION 基本信息

This manual covers the installation, operation and maintenance of Patterson Pump horizontal split case pumps. The pump is a centrifugal, single stage, double suction type. When properly installed and when given reasonable care and maintenance, centrifugal pumps should operate satisfactorily for a long period of time. Centrifugal pumps use the centrifugal force principal of accelerating the liquid within a rotating impeller, and then collecting it and converting it to pressure head in a stationary volute.

本手册主要是针对美国帕特森生产的单级卧式离心双吸泵安装, 操作和维护说明。正确的安装, 维护和保养, 设备应该可以正常运行很长一段时间。离心泵一般由驱动器驱动, 在启动泵前, 泵体及吸入管路内充满液体。当叶轮高速旋转时, 叶轮带动叶片间的液体一道旋转, 由于离心力的作用, 液体从叶轮中心被甩向叶轮外缘, 动能也随之增加。当液体进入泵壳后, 由于蜗壳形泵壳中的流道逐渐扩大, 液体流速逐渐降低, 一部分动能转变为静压能, 于是液体以较高的压强沿排出口流出。叶轮不停旋转, 液体也连续不断的被吸入和压出。由于离心泵之所以能够输送液体, 主要靠离心力的作用, 故称为离心泵。

The pump consists of two assemblies:

这个泵包含两类组件:

1. Casing assembly or stationary part
泵壳装配体或静止部件
2. Rotating element or moving part
旋转组件或动部件

This casing is split along the horizontal centerline of the pump shaft, suction and discharge nozzles both being located in the lower half. With this arrangement, it is not necessary to disconnect suction or discharge piping to make repairs to, or replace the rotating element. Upper and lower half casings are bolted together and doweled to maintain a smooth volute contour inside the pump. Supporting feet are integrally cast in the lower half casing and are drilled for bolting and doweled to base plate. Bearing brackets form a drip pocket for collecting stuffing box leakage and are provided with drilled and tapped connections for draining. The brackets also contain an overflow hole to release the water before it reaches the shaft, in case drain piping should become clogged. Suction and discharge flanges are drilled and tapped for gauge connections. Pump suction and discharge nozzles are drilled and tapped on the underneath side for complete pump drain. Wear rings are provided to minimize internal bypassing of the liquid being pumped, and to better efficiency, as well as to reduce the replacement of major components (such as casing and impeller).

泵壳是沿着泵轴水平中心线分开, 泵入口和出口法兰均是在泵壳的下半部分。对于这样的布置, 无需断开或拆卸泵出口或入口的管道来进行维修或更换泵的旋转部件。泵上部泵壳和下部泵壳是通过螺栓连接在一起, 并有定位销连接, 能够确保上下泵壳连接后泵内轮廓蜗形光滑。泵的支腿是和泵壳下半部分整体铸造, 支腿有钻好的栓孔以便螺栓和销钉连接泵基座。轴承支架与泵壳体之间形成一个泄漏水滴收集槽, 收集槽有接口可连接排水管道; 以防排水管道堵塞, 收集槽有一个溢流孔, 在水位到达轴之前将水溢流出去。泵体入口和出口法兰上均有钻好并带螺纹的接口来连接压力表, 在泵入口和出口法兰低档处设有钻好并带螺纹的接口以便泵体内排空。泵体内承磨环可以避免过多的水从叶轮与泵壳间的缝隙流出, 也可以降低更换如泵壳和叶轮等主要泵零件的频率。

SECTION II 第二部分 STORAGE & PROTECTION 储存和保护

All pumps are shop serviced and ready for operation when delivered, but there is occasions when considerable time elapses between the delivery date and the time the pump is put into operation. Equipment, which is not in service, should be kept in a clean, dry area. If equipment is to be stored for long periods of time (six months or more), the following precautions should be taken to insure that the equipment remains in good condition.

所有设备当交付的时候都处于可运行状态。当设备交货到泵投入运行间隔时间过长的情况下，未投入运行的设备应该保存在一个清洁、干燥的区域。如果设备长期存放 6 个月以上，应采取下面的预防措施来确保设备仍处于良好的状态。

1. Be sure that the bearings are fully lubricated.
确保轴承完全被润滑。
2. Unpainted-machined surfaces, which are subject to corrosion, should be protected by some corrosive resistant coating.
未上漆的表面，易受到腐/锈蚀，应该刷涂些防腐/锈蚀涂料来保护。
3. The shaft should be rotated 10 to 15 revolutions by hand periodically in order to spread the lubricant over all the bearing surfaces. Suitable intervals are from one to three months, depending on atmospheric conditions, etc. In order to insure that the pump shaft does not begin to sag, do not leave the shaft in the same position each time.
应定期手动旋转轴 10 到 15 圈，以确保轴承完全被润滑脂/油润滑。取决于气候等条件，合适的间隔时间是一到三个月。为了确保泵轴不变形，不要每次将轴旋停在同一位置。
4. Space heaters on motors and controllers should be connected and fully operable if atmospheric conditions approach those experienced in operation. Consult instruction manuals for other precautions concerning storage of individual components of pumping unit.
在设备长时间储存后进行安装或投入使用前需要将电机加热器或者控制柜加热器开启并使其达到预期工作状态。请咨询或查阅有关系系统主要设备或者零件手册关于存储的其他预防措施。
5. Fresh lubricant must be applied to bearings upon removal of equipment form storage.
在设备长时间储存后进行安装或投入使用时，轴承上必须换上新的润滑油/脂。

SECTION III 第三部分 INSTALLATION 安装

3-1 Location: 位置

Several factors should be considered when selecting a location for the pumping unit (pump, base, drive, and coupling). The unit should be accessible for both inspection and maintenance. Headroom should be provided for the use of crane, hoist or other necessary lifting devices. The pump should be located as close as possible to the liquid supply so that the suction line is short and direct. Location should require a minimum of elbows and fittings in the discharge line to minimize friction losses. The unit should be protected against flooding.

当为水泵机组(包括泵、基座、驱动器和联轴器)选择一个安装位置,应考虑以下几个因素:机组应便于检查和维修;泵房顶部应该配置吊车,起重机或其它必要的起重设备。泵应该尽可能接近供水端的位置安装,以便供水更直接和快速。泵出口管道应该尽量减小的弯头及其他管件,以减少摩擦损失。机组位置应有防止设备被淹的保护措施。

3-2 Foundation: 基础

The foundation should be sufficiently substantial to absorb vibration and to form a permanent rigid support for the base plate. Concrete is most widely used for foundation. Before pouring the foundation, locate anchor bolts per outline drawing. Allow for 3/4 inch to 1 1/2 inch of grout between foundation and base plate. The top surface of the foundation should be roughened to provide a good bond for the grout.

泵设备基础应该足够稳固以吸收振动,并能够形成一个永久性的刚性支撑底座。比较广泛的是采用混凝土基础。在浇注基础之前,在可以参照设备外形尺寸图中的地脚螺栓位置预埋螺栓。在混凝土基础和设备基座之间预留 3/4 英寸(20mm)到 1-1/2 英寸(40mm)的二次灌浆高度。混凝土基础顶部表面应该为二次灌浆提供良好的表面粗糙度。

3-3 Mounting: 就位

WARNING!!! Do not attempt to lift entire unit using lugs provided on either pump or motor only. Such action may lead to failure of the lugs and possible damage to the unit or injury to personnel. Lift unit with slings around the base plate, or by attaching cables to the lifting lugs on both the pump and the motor.

警告!!! 不要试图使用泵头或电机上的吊耳将整个泵机组吊起。这样的操作可能会导致吊耳失效,损坏设备或使人员受伤。起重机器与吊索应放置在泵机组钢制基座上,或通过泵和电机吊环附加缆绳。

Coupling halves should be disconnected when mounting the pumping unit on the foundation. Wedges should be used to support the unit at the time of grouting. Wedges should be located adjacent to anchor bolts (one on each side of bolt) and midway between bolts. Adjust the wedges to raise or lower the unit as required to align suction and discharge flanges to piping and to level the base plate. Leveling bolts made of cap screws and nuts are useful when leveling large base plate, but should not replace shims or blocks for supporting the load. After unit has been in operation for about a week, check alignment. After making any required adjustments, dowel pump and motor to base.

当在混凝土基础上安装泵机组时,联轴器应该被断开。在二次灌浆固定设备基座时,可以使用斜垫铁来垫高或调平泵机组。垫铁的位置可以靠近设备基座的地角螺栓,在每个地角螺栓的一侧和两两脚螺栓之间放置。当校平设备基座时,特别在校平大型设备基座时,可以通过使用调平螺栓,但是调平螺栓不能够替代支撑设备荷载的地角螺栓。在机组运行了大约一个星期之后,检查需要重新二次校准水平及泵电机对中。在完成所需调整之后,需要将泵和电机重新紧固于设备基座上。

3-4 Alignment: 校准对中

The pump unit has been manufactured to allow field alignment. The unit must be properly aligned at the time of installation. Reliable trouble-free and efficient operation of a unit depends upon correct alignment. Misalignment may be the cause of noisy pump operation, vibration, premature bearing failure, or excessive coupling wear. Factors that may change the alignment of the pumping unit are settling of the foundation, springing of the base plate, piping strains, a shift of the pump or drive on the foundation. When checking coupling alignment, remember flexible couplings are not intended to be used as universal joints. The purpose of a flexible coupling is to compensate for temperature changes and to permit end movement of the shafts without interference with each other.

泵机组生产后是需要到现场安装时进行联轴器二次校准对中的，而且安装就位后任何时候都要确保联轴器必须处于正确的对中。联轴器正确的校准对中是确保机组可靠的，高效的运行和设备少故障基石。未完全的联轴器校准和对中可能会导致泵在运行时噪音增大、振动加大、轴承过早损坏或联轴器过度磨损等等众多的故障，同时也可能导致泵基座脱离混凝土基础，泵基座震颤、管道应力加大、设备基座上泵或电机的位移或者脱离。当检查联轴器对中时，注意不要错误的将弹性联轴器当做万向节联轴器来进行对中。弹性联轴器仅仅是为了补偿温度变化而存在的轴端位移，保证轴端与轴端之间不相互接触。

Two types of misalignment may exist: parallel misalignment and angular misalignment. Limits of misalignments are stated in the coupling manufacturer's instructions, but should be kept to a minimum for maximum life of equipment components.

可能存在两种类型的对中偏差：平行度偏差和角偏差。偏差的限制范围在联轴器生产厂家的使用说明中有介绍，应该保持偏差在最小允许范围内，以使设备组件有更长的使用寿命。

To check coupling alignment, the following procedure should be followed:

检查联轴器的对中，应遵循下面的程序：

1. Set the coupling gap to the dimension shown on the outline drawing.
按照设备外形尺寸图中标注的尺寸检查联轴器连接件（靠背轮）之间的间隙。
2. Check for parallel misalignment by placing a straight edge across both coupling halves at four points 90° apart. Correct alignment occurs when the straight edge is level across the coupling halves at all points.
可以使用钢质直尺横跨联轴器两个连接件（靠背轮）90度的四个位置，来观察和确认联轴器水平度对中和偏差。如果直尺在四个不同90度位置两个连接件（靠背轮）间隙一致，可以认为联轴器水平对中正确。
3. Check angular misalignment with a feeler gauge at four points 90° apart. Correct alignment occurs when the same gauge just enters between the halves at all four points.
可以使用钢质塞尺测量联轴器两个连接件（靠背轮）90度四个位置的间隙，来观察和确认联轴器角度对中和偏差。如果塞尺在四个不同90度位置两个连接件（靠背轮）间隙一致，可以认为联轴器角度对中正确。

Angular and parallel misalignment are corrected by shifting the motor and adding or removing shims from under the motor feet. After each change, it is necessary to recheck the alignment of the coupling halves. Adjustment in one direction may disturb adjustment already made in another direction.

角偏差及平行度偏差可以通过移动电动机和添加或移除电动机的脚下的垫片来进行纠正。每一次调整之后，有必要重新检查联轴器的对中情况。任何一个方向的调整都可能干扰到另一个方向已经做过的调整。

An alternative method for checking coupling alignment is by use of a dial indicator. Proceed as follows:

另一种方法是通过使用千分表检查联轴器的对中。按如下步骤操作:

1. Scribe index lines on coupling halves or mark where the indicator point rests.
标记一条直线横跨两个联轴器连接件（靠背轮），或者标定两个联轴器连接件（靠背轮）放置千分表的测量位置。
2. Set indicator dial to zero.
将千分表表盘调零。
3. Slowly turn both coupling halves so that the index lines match, or the indicator point is always on the mark.
慢慢地同时旋转两个联轴器的连接件（靠背轮），确保标记的直线没有错位，或标定千分表的测量位置没有变化。
4. Observe dial reading to determine whether adjustments are needed. Acceptable alignment occurs when total indicator reading does not exceed 0.004 inches for both parallel and angular alignment.
观察表盘读数来判断是否需要调整。在平行度偏差和角偏差的总读数不超过 0.004 英寸时，联轴器的对中是可以接受的。

The importance of correct alignment cannot be overemphasized. Alignment should be checked and corrected as required after:

正确对中的重要性再怎么强调都不为过。在以下情况之后需要重新检查并校准对中:

1. Mounting 安装就位
2. Grouting has hardened 二次灌浆完成并固化
3. Foundation bolts are tightened 设备基座固定螺栓紧固完成
4. Piping is connected 设备连接管道
5. Pump, driver, or base plate is moved for any reason.
任何情况下泵、电机、基座的挪动

WARNING!!! 警告!!!

The importance of correct alignment cannot be overemphasized. The following procedure should be used for initial installation.

正确对中的非常重要。在初始安装时，应该遵循下列程序：

1. Place complete pump assembly on anchor bolts allowing room under the base plate for leveling wedges or shims. Make sure the base plate is level by using the leveling wedges adjacent to the foundation bolts and midway between the bolts.
在设备机组就位时留出空间放置调整垫铁或垫片。使用水平尺确保设备基座就位水平。
2. Put nuts on the anchor bolts and tighten evenly, but not too tight.
均匀拧紧设备基座上的地脚螺栓螺母，但不要太紧。
3. At this point check alignment of the coupling. This should not be more than that recommended by the coupling manufacturer.
这时需要校准对中设备联轴器。确保联轴器对中不超过联轴器制造商允许的偏差范围。
4. If misalignment is evident, determine which direction the coupling needs to be moved.
如果偏差很明显，确定联轴器哪些方向需要移动。
5. Loosen all nuts and add the shims underneath the base plate at the opposite corners. Use the anchor bolts to flex the base plate to bring the coupling into alignment.
松开所有设备的螺母，调整必要的设备位置完成对中。
6. After the alignment has been made with all anchor bolt nuts tight, the grouting can take place.
联轴器完成对中后，拧紧所有螺栓及地脚螺栓，可以进行二次灌浆。
7. After grouting is completed, final alignment should be checked to be sure it is within allowable tolerances. Use of shims under the driver can be used to obtain final alignment.
在二次灌浆完成后，最终需要检查一下联轴器的对中，以确定它是在允许的偏差范围内。调整电机支脚下的垫片可以得到最终的对准。

Alignment should be checked and corrected as required after:

以下情况之后，要求检查并重新校准对中：

- Mounting 安装就位
- Foundation bolts are tightened 基础螺栓已紧固
- Grouting has hardened 灌浆已经硬化
- Piping is connected 管道已经连接
- Pump, driver, or base plate is moved for any reason 泵、电机、或基座任何移位

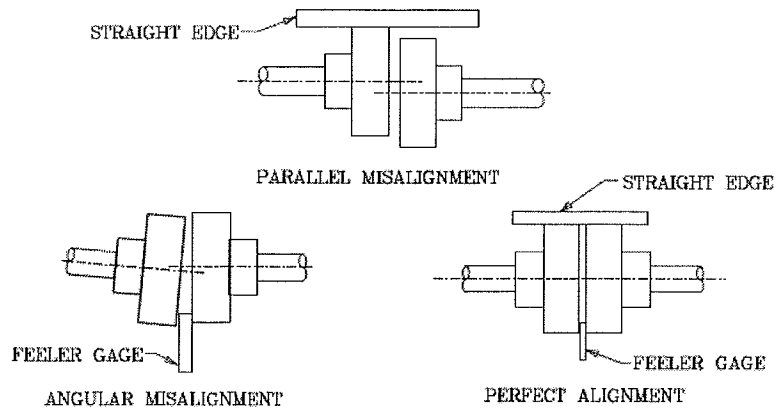

FIG.1 TESTING ALIGNMENT, STRAIGHTEDGE

图 1 使用直尺检查水平偏差和塞尺检查角偏差

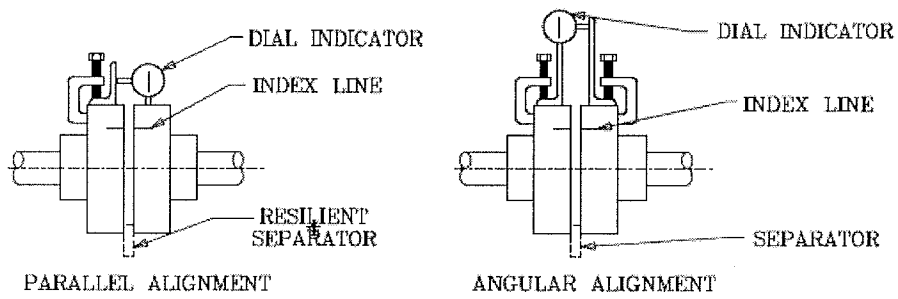

FIG.2 TESTING ALIGNMENT, DIAL INDICATOR

图 2 使用千分表检查对中

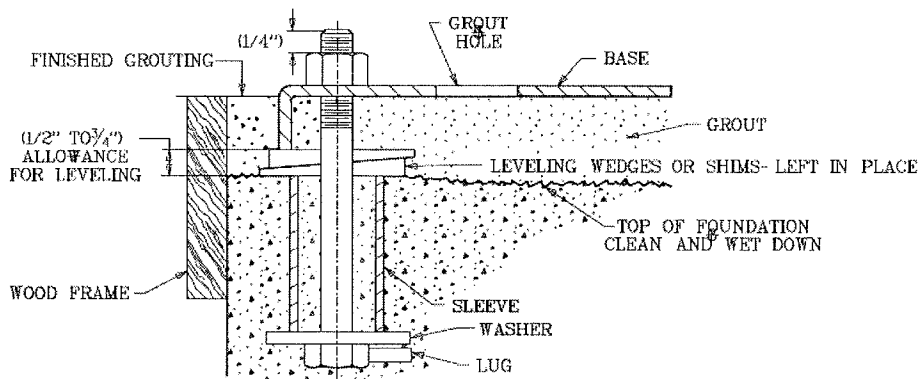

FIG.3 TYPICAL FOUNDATION BOLT DESIGN

图 3 典型的地脚螺栓安装示意

3-5 Grouting: 二次灌浆

Grout compensates for unevenness in the foundation and distributes the weight of the unit uniformly on the foundation. It also prevents lateral shifting of the base plate and reduces vibration. Use a non-shrinking grout. Foundation bolts should be tightened evenly, but not too firmly. Grout the unit as follows:

设备基座二次灌浆可以对混凝土基础不平整进行补偿和修正，使上面的机组重量荷载更均匀的分布。它还可以防止设备基座的横向偏移和减少设备的振动。二次灌浆要使用不收缩的混凝土或者浆灰。地脚螺栓应均匀拧紧，但不应过紧。设备基座的二次灌浆应按照如下方式：

1. Build a strong form around the base plate to contain the grout.
在设备基座周围设置牢固的模板来进行灌浆成型。
2. Soak the foundation top thoroughly, and then remove surface water.
原混凝土基础表面需要洒水或者浸湿，但是表面不能有存水。
3. Pour grout. Tamp liberally while pouring in order to fill all cavities and prevent air pockets. The space between the foundation and base plate should be completely filled with grout. In order to prevent the base plate from shifting, fill under the base plate at least four inches in from all four edges. Wedges may be left in place.
在灌浆时需要充分夯实以填满所有孔洞并防止气穴存在。混凝土基础和设备基座之间的缝隙或空间应该完全注满。为了防止设备基座移动，设备基座四面需要至少保证4"（100mm）宽的灌浆尺寸。原有基座下方的垫铁或者垫块可能需要保留。
4. After the grout has hardened (usually about 48 hours), thoroughly tighten foundation bolts and check alignment.
在灌浆硬化后(通常约48小时)，彻底拧紧基础螺栓，检查联轴器校准对中。
5. Approximately 14 days after the grout has been poured or when it is thoroughly dry, apply an oil base paint to exposed edges of the grout to prevent air and moisture from coming in contact with the grout.
灌浆之后大约14天，当混凝土或者浆灰彻底干燥后，应用一种油基油漆在灌浆暴露的表面进行刷漆/涂刷，以防空气和水分接触灌浆。

3-6 Piping: 管道连接

Connect pipelines after the grout has thoroughly hardened. The suction and discharge piping should be installed with the shortest and most direct runs. Elbows should preferably be of the long radius type. Pipes must line up naturally. The piping must never be pulled into position by the flange bolts. Such action may draw the pump out of alignment. Pipes should be support independently of the pump so as not to put any strain on the pump casing. Suction piping, if not properly installed, is a potential source of faulty operation. Suction lines should be free of air leaks, and arranged so there are no loops or high spots in which air can be trapped. Generally, the suction line is larger than the pump suction nozzle, and eccentric reducers should be used. Eccentric reducers are not necessary for bottom suction pumps. If the liquid supply is located below the pump centerline, the reducer should be installed with the straight side up.

在灌浆彻底硬化后连接管道。泵入口和出口管道的布置应该以最短、最直接的方式走向和布置。管道弯头尽可能使用长半径类型的。为避免影响泵联轴器对中，泵连接的管道不能对泵有任何外加应力的施加，而且与泵连接的管道不能使用法兰螺栓强行拉伸强行就位。与泵连接的管道应该有独立的支撑，不能靠泵壳进行管路支撑，以免给泵壳增加应力导致泵壳破坏。入口管路的布置非常重要，如果没有正确安装和走向，将会导致泵运行故障和影响泵的性能表现。入口管路不应存在可吸入空气的可

能，并设计没有循环或高点导致气室的产生布置。通常泵入口管路管径应大于泵的入口管径，而且应该使用向泵中心线下方偏向的偏心变径接头。供水管路从泵的下端反弯连接泵入口，不需要偏心变径接头。如果泵前端进水管从下翻弯接入，泵入口变径应使用同心变径并直立安装。

Most often air enters the suction pipe entrained in the liquid. Installations with a static suction lift preferably should have the inlet of the vertical suction piping submerged in the liquid to four times the piping diameter. A large suction pipe will usually prevent the formation of vortexes or whirlpools, especially if the entrance is flared (Figure 5). A floating vortex breaker (raft) around the suction piping may be provided if a tendency appears for a vortex to form at the liquid surface. A stream of liquid falling into the sump near the intake pipe will churn air into the liquid (Figure 6). The supply line should extend down into the sump. Liquid supply entering a well perpendicular to the intake line tends to rotate the liquid, which interferes with the flow into the suction line (Figure 7). A baffle placed in front of the supply pipe will remedy this situation. A short elbow should never be bolted directly to the pumps suction nozzle. The disturbance in the flow caused by the sharp bend so near the pump inlet may result in noisy operation, loss in efficiency, and capacity, and heavy end thrust.

通常情况空气会随着水流从泵入口管路吸入端一并带入泵体。浸没在蓄水液面下的入水口位置应该有保证有四倍管径的潜没深度。通常大口径入水管路或者在入水口设置喇叭口会防止在入水口形成涡流或漩渦(图 5)。如果在液面出现涡流趋势，在入口管道周围可能需要浮动的防涡流挡板(筏)。当蓄水池蓄水管路或回流水管水流在池中靠近泵吸入口管路附近，会把空气带入水中(图 6)，蓄水管路或者回流管路应该延伸到集水坑。蓄水管路或者回流管路的水流若垂直于吸水管路往往会搅拌水流，会影响入口的水流(图 7)。蓄水管路或者回流管路口加装挡板或者隔板的方法是可以阻止其搅拌水流。禁止泵入水口/端直接连接短半径弯头。短半径弯头会在泵进口处形成进水扰流，可能导致设备运行噪声增加，降低设备运行效率、降低设备性能表现，并加大泵轴向的推力。

A long sweep or long radius elbow placed as far away from the pump as practicable should be used if a bend is necessary in the suction line. If separate suction lines cannot be used for each pump, then a tapering header with Y-branches should be used (Figure 8A). A straight branch header should never be used. Prior to installing the pump, suction piping and pump should be inspected internally, cleaned and flushed. If a strainer is installed in the suction line, the openings in the screen must be checked and cleaned periodically. The opening must be smaller than the sphere size allowed by the impeller.

如果泵入口管路必须加装弯头，在尽可能远离泵的位置，并使用长半径弯头。在有多台泵同时连接供水汇流管路时（每台泵入口管路不能单独独立从蓄水池中引出时），应在汇流管上使用 Y 型分支的三通接头(图 8)，不可使用正接三通。安装泵之前，应检查吸水管路和泵的内部并清洁冲洗。如果入水管路上装有过滤器，滤网的网孔必须定期检查和清洗，网孔尺寸必须小于叶轮所允许通过的粒度尺寸。

Discharge piping should be installed with check valve and gate valve, with the check valve being between the pump and the gate valve. The check valve prevents reverse flow and protects the pump from excessive backpressure. The gate valve is used to isolate the pump for maintenance, priming and starting. If a diffuser is used, it should be placed between the pump and check valve.

泵出口管道应安装止回阀和闸阀，止回阀安装在泵和出口闸阀之间。止回阀可以防止水流回流并在系统回流压力过大时保护泵体。闸阀用于泵维护、测试和启动时保证与系统管网隔离。如果使用导流阀，它应该被安装在泵和止回阀之间。

Stuffing box seal connections are usually made from the top of the pump casing. If the liquid being pumped is unsuitable for sealing, then it is preferable to bring fresh, cool water to seal connections from an outside source. Centrifugal separators or other filters may be used to remove abrasive particles from the liquid being pumped if an outside source is not available. After all piping connections have been made, the alignment should be checked again.

通常在泵壳的顶部有连接填料函密封冲洗冷却用水管。如果泵中的水流不适合密封冲洗冷却，需要从外部单独引入密封冲洗冷却用水。如果无法获得或不可使用外部水源，在泵密封冲洗冷却水管中加装离心式分离器或其他过滤器以去除污浊或粗糙的颗粒。所有管道连接后，应再次检查对齐。

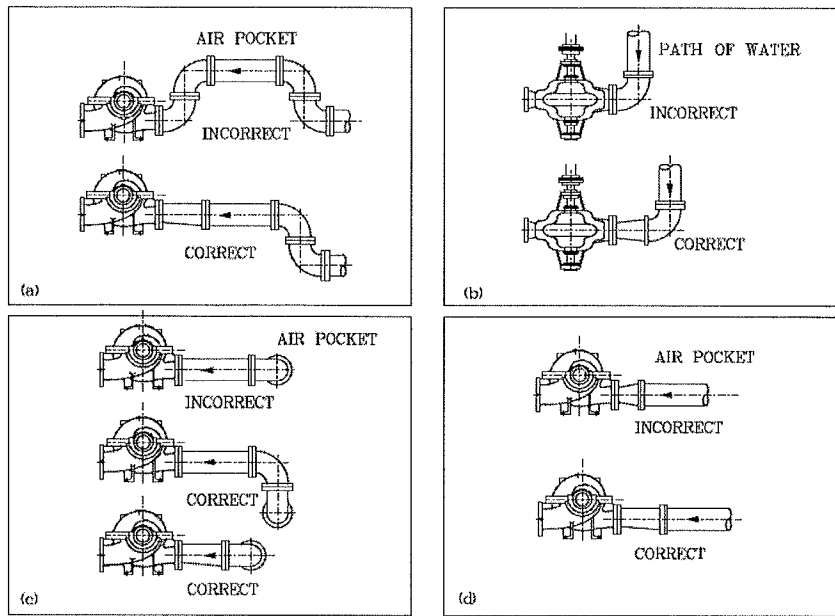

FIG.4 SUCTION PIPING ARRANGEMENTS

图 4 入口管路的布置

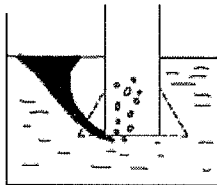

FIG.5 Enlarging the suction pipe usually prevents whirlpools and the resultant entrance of air into the pipes

图 5 通常加大入口管径防止漩涡带入空气进入管道

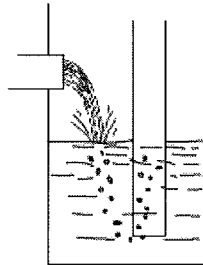

Fig.6(a) Water falling into sump churns air into the sump liquid and causes trouble in the suction line.

图 7(a)蓄水或回流管路水流进入池中搅动带入空气进入供水管路,引起入口管路问题。

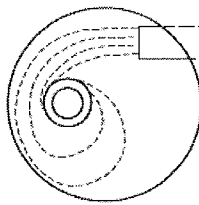

Fig. 7

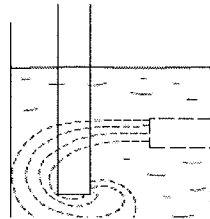

Fig.6(b) Supply line should extend down into the sump to prevent the churning of air into the water.

图 6(b)供给管路应该伸到底部,防止搅拌使空气进入水中。

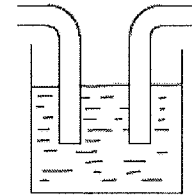

Fig.7 Rotation of water in the well, as illustrated, can be prevented with a baffle.

图 7 井中水旋转,如图所示,可以使用挡板预防。

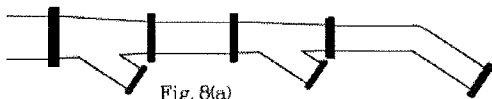

Fig. 8(a)

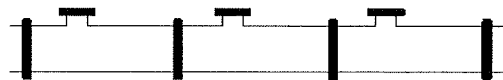

Fig. 8(b)

Fig.8(a) Shows the tapering header which should be used if two or more pumps are served with one intake line. The pipe shown in FIG.8(b) should never be used.

图 8(a)显示了如果两个或两个以上的泵共用汇流供水管正确的连接方法。

图 8(b)中所示的汇流管供水方式不应该被使用。

SECTION IV 第四部分 OPERATION 操作

Before bolting the coupling halves together, check the drive rotation to see that it matches the pump rotation. Pump rotation is indicated by an arrow attached to the casing assembly. For a three-phase motor, rotation may be reversed, if necessary, by interchanging any two of the three power leads. Rotation of single-phase motors is fixed by internal wiring.

在将联轴器两个连接件（靠背轮）用螺栓连接前，检查电机的转动方向是否与泵轴的转动方向一致。泵壳上有箭头标示泵的转动方向。对于三相电机，可能会反转，如果有必要，可以将三相的电源中的任意两相互倒换下以达到正转的要求。

WARNING!!! Prior to startup, check the coupling alignment as covered in the **Installation Section**. Operation of the pump with the unit misaligned will cause damage to the shaft, bearings, and the coupling.

警告!!! 启动前，按照安装部分的说明检查联轴器对中。联轴器未对中时运行泵将会造成轴、轴承、联轴器的损坏。

4-1 Starting: 启动

- When possible, turn the pump shaft by hand to insure that the parts do not bind
如果有可能的话，用手转动泵轴来确保泵轴及叶轮旋转正常。
- Check the bearing lubricant
检查轴承润滑
- Open the valve in the pump suction line, if fitted
打开泵入口管路的阀门（如果安装）
- Close discharge valve
关闭出口阀门
- Prime the pump in one of the following ways:
按以下程序注满水于泵体：
 1. If the pump operates under positive pressure, open vent valve on top of the pump casing. After all entrained air has escaped, close the vent valves. Rotate the shaft, if possible, to allow any air trapped in the impeller passages to escape.
如果泵入口有正压，打开泵壳上的排气阀。当所有进入泵内的空气都排出后，关闭排气阀门。如果可以，转动泵轴使所有在叶轮内的空气排出。
 2. If the pump operates on a suction lift and a foot valve is included in the system, fill the pump and the suction line with liquid from an outside source. Trapped air should be allowed to escape through the vent valve while filling.
如果泵入口有吸程，并且泵吸入管口有安装底阀。需要从外部水源将入水管道和泵内灌满。当灌水时，需要有排气的地方。
 3. If the pump operates on a suction lift and no foot valve is provided, use a vacuum pump or ejector operated by air, steam, water, etc. to evacuate air from the pump case and suction line by connecting the ejector to the priming connection on top of the pump case.
如果泵入口有吸程，并且泵吸入管口没有安装底阀。使用真空泵或其他方式驱动的水器，将注水器连接到泵壳的顶部来排出泵内和吸水管路内的空气。

Open valves in stuffing box seal lines, if fitted. Start driver. Open discharge valve slowly when the pump is up to speed.

打开填料函冲洗管路阀门（如果安装）。启动驱动机。当泵全速运转时慢慢打出口阀门。

CAUTION: Overheating and/or loss of prime will result if the pump is operated against a closed valve for more than a few minutes.

小心:如果泵在泵出口阀门关闭状态下运行超过几分钟,会导致泵体过热和/或泵内进入空气。

WARNING !!! The coupling guard should be in place when the unit is started. Stay clear of any exposed rotating parts while the pump is operating. Contact with rotating parts may result in injury to personnel.

警告!!!当机组启动时,联轴器保护罩应该放置到位。当泵运行时远离任何暴露的旋转部件。接触到任何的旋转部件可能导致人员受伤。

Adjust the packing gland until there is a slight leakage from the stuffing box. **(See Maintenance on Adjustment of Packing)**. Mechanical seals need no adjustment. There should be no leakage.

调整填料压盖至填料处有少量泄漏。(参见填料密封的维护说明)。机械密封不需要调整,机械密封应没有泄漏。

NOTE: Should the pump fail to build up pressure or discharge water when the discharge valve is opened, stop the pump and read **Section Locating Operating Difficulties**.

注意:当泵出口阀门打开后没有压力或没有水流,应该立即停止泵并阅读本说明书操作难点部分。

4-2 Shutdown 停机

The pump may be stopped with the discharge valve open without causing damage. However, in order to prevent water hammer effects, the discharge valve should be closed first.

泵可以在出口阀打开时停止并不造成损坏。为了防止水锤,出口阀门应首先关闭,再停泵。

1. Close discharge valve.
关闭出口阀门。
2. Stop driver.
停止电机。
3. Close water seal valves.
关闭密封冲洗管路阀门。
4. Close valve in the pump suction line, if fitted. If danger of freezing exists, drain the pump completely.
关闭泵入口阀门（如果安装）。如果需要防止冰冻的危险,需要将泵中的水完全排干。

4-3 Minimum Flow Limitation 最小流量的限制

All centrifugal pumps have limitations on the minimum flow at which they should be operated. The most common limitation is to avoid excessive temperature buildup in the pump because of absorption of the input power into the pumped fluid. Other less understood reasons for restrictions are:

所有离心泵都有最小流量运行的限制。这种限制是为了避免泵中输入水流的能量积累产生温度过高。存在这种限制的原因如下:

1. Increased radial reaction at low flows in single volute casings.
低流量时会在泵单蜗壳内增加径向反作用力。
2. Increased NPSHr at low flows.
在低流量时必须的汽蚀余量 NPSHr 增加。
3. Noisy, rough operation and possible physical damage due to internal recirculation.
水在泵内部的循环会产生噪音，运行不流畅和可能的物理损伤。
4. Increased suction and discharge pulsation levels.
增加泵入口和出口的冲击波动。

The size of the pump, the energy absorbed, and the liquid pumped are among the considerations in determining these minimum flow limitations. For example, most small pumps such as domestic home circulators, service water pumps, and chemical pumps have no limitations, except for temperature buildup considerations while many large, high horsepower pumps have limitations as high as 40-50% of the best efficiency point capacity. The minimum safe flow for this pump is given under **Pump Specifications**.

泵的最小流量的限制值是根据泵的尺寸，能量吸收和流体介质等多个因素来决定的。大多数小型泵如家用循环设备，家用生活用水泵，化工用泵没有最小流量的限制。除了考虑温度因素，在许多大尺寸和大马力泵的应用中，这种最小流量的限制甚至在泵最佳效率点的 40 - 50% 范围内。在泵规格书有列明最低（小）安全流量。

SECTION V 第五部分 MAINTENANCE 维护

5-1 Lubrication: 润滑

Couplings: Couplings with rubber drive elements do not require lubrication. Most other couplings require some form of lubrication. Consult manufacturer's instructions for recommendations.

联轴器: 带橡胶软体的联轴器不需要润滑。大多数其他类型的联轴器需要某种形式的润滑。参考联轴器制造商的指导建议。

Bearings: Frequency of lubrication depends upon operating conditions and environment, therefore, lubrication intervals must be determined by experience. Table I may be used as a general guide for grease relubrication. Lubricants need replacing only because of contamination by dirt or dust, metal particles, moisture or high temperature breakdown. A small amount of grease may be added about every 400 hours of operation. The bearing housing should be about 1/3 full of grease. Oil lubricated units are provided with constant level oilers. Bottles should be kept filled at all times so that there is a visible supply of oil. All lubricants have a tendency to deteriorate in the course of time, therefore, sooner or later it will be necessary to replace the old lubricant with new. Bearings, which are dismantled, are, of course, much more easily cleaned than bearings, which stay in assembled equipment. Solvents may be used more freely and effectively. For cleaning bearings without dismounting, hot light oil at 180° - 200° F may be flushed through the housing while the shaft is slowly rotated. Light transformer oils, spindle oils, or automotive flushing oils are suitable for cleaning bearings, but anything heavier than light motor oil (SAE 10) is not recommended. The use of chlorinated solvents of any kind is not recommended in bearing cleaning.

轴承: 轴承润滑频率取决于操作条件和环境。润滑要求间隔时间需要根据现场环境及设备运行的观察来确定。表一可以作为轴承润滑周期的大概指导时间。如果润滑油/脂含有被污染、污垢、灰尘、金属颗粒、水分或被高温分解的情况,需要完全更换现有的润滑油/脂。大约每运行 400 小时需要添加少量的油/脂。轴承室应保有 1/3 油脂的填充。油润滑的轴承在轴承室上配有自动加注桶。加注桶应一直保持灌满,加注桶是一个透明的,可以随时观察润换油的液位。所有润滑油/油脂经过一定的时间都会有变质,因此需要周期性更换。将轴承拆下用清洗溶剂来清洗比轴承装配在设备上清洗会容易得很多。如果不拆下来清洗轴承时,慢慢旋转泵轴并使用 180°- 200°F 热的低粘度油冲洗轴承室。低粘度传动油、轴润滑油或汽车用的清洗溶剂均适用于清洗轴承,不可使用任何比低粘度油(SAE 10)粘度高的油和不可使用任何形式的氯化溶剂来清洗轴承。

Grease Relubrication: (pumps are shipped with grease in bearing housings)

润滑脂重新添加:(泵出厂时泵的轴承室已经含有润滑脂)

1. Thoroughly clean grease fitting and outside of bearing housing.
彻底清洁润滑脂加注嘴和轴承座外部。
2. Remove drain plug.
拆掉轴承室的排油堵头。
3. Inject clean, new grease forcing out the old.
注入干净,新的润滑脂来代替旧的。

4. Start and run the pump for a short time to eject any excess grease.
短时间的启动运行泵挤出多余润滑脂。
5. Wipe off all excess grease and replace drain plug.
清除所有多余的润滑脂和装好排油堵头。

Oil Relubrication: (pumps are shipped without oil in bearing housing)
润滑油润滑:(泵的轴承室不附带润滑油)

1. Remove drain plug and allow any residue oil to completely drain.
打开放油塞使所有残余油完全流出。
2. Remove constant level oiler bottle and clean thoroughly.
拆下注油桶并彻底清洁。
3. Replace drain plug.
更换放油塞。
4. Fill bottle, screw it to the lower reservoir of oiler and allow oil to flow into bearing housing reservoir. Repeat this procedure until a supply of oil remains in the bottle.
加注润滑油到注油桶,将注油桶装载轴承处,重复几次后将轴承室灌满润滑油直到注油桶内能保存有润滑油液位。

For ball bearings, the oil level should be at about the middle of the lower most ball. For ring oiled sleeve bearings, the oil level should be about 1/8 inch over the lowest point of the oil ring.
对滚珠轴承,油位应在最低球位置中间处。对油环润滑式滑动轴承,油位应高于油环最低点大约 1/8 英寸的位置。

WARNING !!! Proper lubrication is essential to the pump operation. Do not operate the pump if sufficient lubricant is not present in the bearing housing or if lubricant is contaminated with excessive dirt or moisture. Operation of the unit under these conditions will lead to impaired pump performance, and possible bearing failure. Do not operate the pump with excessive amount of lubricant. Such action will cause bearings to overheat.

警告!!!适当的润滑对于泵的运行是至关重要的。如果轴承座中润滑油/脂不足或润滑油/脂含有过多的灰尘或水分,不要运行泵。在这类状况下运行设备将影响其性能表现并可能导致轴承损坏。在润滑油/脂过多也不建议运行设备,这样会引起轴承过热。

5-2 Stuffing Box: 填料函

The purpose of a stuffing box is to limit or eliminate leakage of the pump fluid and to prevent air from entering the suction spaces along the pump shaft. Pumps are equipped with packing (limited leakage) or mechanical seals (no leakage). Normally, the pumped liquid is used to lubricate the stuffing box seal. If the liquid is dirty, gritty, or contains material that would gum or jam the seal, use a sealing liquid from an external source. If suction pressure is above atmospheric pressure, seal piping may not be required. For pumps equipped with packing, there must always be a slight leakage from the glands. The amount of leakage is hard to define, but we recommend a steady dripping of liquid through the gland. Stuffing box glands should be adjusted after the pump is started. When leakage is excessive, tighten gland bolts evenly a little at a time. Allow an interval for packing to adjust to new position. Never tighten gland to be leakproof, as this will cause overheating and undue wear on shaft sleeves.

泵填料函的作用是限制或阻止泵与泵轴间的渗水,并且防止空气沿泵轴进入泵体。泵通常配置两种类型的密封,一种是填料函(有轻微渗漏),另一种是机械密封(无渗漏)。正常情况下,润滑填料密封函需从泵内取水来进行冲洗冷却润滑。如果泵内取的水流是带有污垢,有砂砾的,或包含粘结或堵塞密

封的物体，建议从外部水源取水来对密封函润滑冲洗冷却。如果泵的吸程压力高于大气压力，填料冲洗管路可以不需要。对于装有填料密封的泵，从密封压盖处有少量渗漏。渗漏量很难确定，但我们认为渗漏比较稳定而且不喷射是可以接受的。如果需要调整填料密封的压盖，需要先运行泵。当填料密封渗漏比较大的时候，每次可以少许的调整，以便填料在压实后靠里的填料有个调整位置的过程。绝对不允许拧紧填料压盖，使其没有任何渗漏，这样会导致泵轴套过热并损坏。

Replace stuffing box packing as follows:

按如下步骤更换密封填料:

1. Shutdown the pump.
停泵。
2. Take precautions to prevent the driver from being inadvertently started.
采取预防措施防止驱动器存在任何意外的启动。
3. Remove the gland bolt nuts and gland.
拆卸填料压盖螺栓螺母和压盖。
4. Remove and discard old packing rings – note location of lantern ring. When repacking stuffing box, lantern ring must be positioned such that the water seal connection is opposite lantern ring.
拆下填料，并丢弃旧的填料环，注意填料水封环的位置。当重新装入填料时，水封环必须对准填料冲洗管路口的位置。
5. Clean out the stuffing box.
清扫填料函。
6. Inspect shaft sleeve for wear – if it is scored or grooved, it should be replaced.
检查轴套磨损 - 如果它有刻痕或有沟槽，需要更换新的轴套。
7. Make sure the stuffing box bushing (if furnished) is set at the bottom of the box.
确保填料函套环(如果有提供)在填料函的最里端。
8. Insert rings of packing and tap lightly to seat against bushing. Be sure rings are of the proper size and length and installed with cuts staggered. Lantern ring **must** be installed opposite sealing water connection.
放入填料环并将其压入并紧靠套环。确保填料环的大小长度合适，而且环的开口为斜坡开口。水封环需对准填料冲洗管路口。
9. Install gland and tighten, finger tight. With the pump running, adjust gland as described previously. Care should be taken during the first hour of operation to take up on the packing gradually just enough to maintain the required amount of leakage.
安装填料压盖并拧紧。在泵运行时，按前面描述调整压盖。在第一次运行的一个小时内，注意观察填料是否能保持稳定的渗漏量。

If the pump is operated daily, the stuffing box packing should be renewed about every two to three months before it gets hard and scores the shaft sleeves.

如果泵每日都运行，每两到三个月需要更换新的填料，以避免损伤泵轴套。

Mechanical seals should be removed, assembled, and/or adjusted according to the seal manufacturer's instructions. There should be no leakage from the gland if mechanical seals are

used, except for a brief run in period.

如何拆装/调整机械密封需要参照机械密封厂家说明书。如果泵配置的是机械密封，除了短暂启停外，密封处应该没有任何渗漏。

5-3 Wear Ring Clearance: 承磨环间隙

Running fits between wear rings is given under the pump specifications. When these clearances are doubled, or the capacity of the pump is reduced by 5 to 10%, the rings should be renewed. The purpose of these rings is to keep internal bypassing of the liquid being pumped to a minimum. Clearances should be checked periodically and whenever the pump casing is opened. Check with feeler gauge or by direct measurement. Measure ID of case ring and OD of impeller ring, then compute clearance (ID minus OD).

泵的规格文件中有描述说明允许的承磨环的间隙。如果间隙超过该运行值一倍，或者泵性能有5%~10%的衰减，应该更换新的承磨环。承磨环的作用是尽量减少水从泵叶轮与壳体间隙跑水。承磨环的间隙需要定期地检查，每次打开泵壳都需要检查和测量。使用塞尺或通过直尺直接测量检查。测量泵壳承磨环的内径和叶轮承磨环的外径，然后计算其间隙(内径 ID 减去外径 OD)。

TABLE 1 表 1
 SUGGESTED RE-LUBRICATION INTERVALS FOR VARIOUS ENVIRONMENTAL, OPERATING AND TEMPERATURE CONDITIONS (环境、运行和温度状况)
 (GREASE LUBRICATED BEARINGS) (润滑脂润滑轴承)

AMBIENT CONDITIONS 环境状况		OPERATING CONDITIONS 运行状况		BEARING OPERATING TEMPERATURE 轴承运行温度		SUGGESTED GREASING INTERVALS** 建议润滑间隔周期	USE THESE GREASES 使用下列润滑脂
Dirt	Moisture	Load	Speed	Low	High		
Clean	Dry	Light to medium	Slow to medium	0°F (-18°C)	120°F (49°C)	2 to 6 months	High quality NGLI No. 1 or 2 multipurpose bearing greases are generally satisfactory. Consultation with a reputable lubricant supplier is recommended.
Moderate to dirty	Dry	Light to medium	Slow to medium	0°F (-18°C)	120°F (49°C)	1 to 4 weeks	
				120°F (49°C)	200°F (93°C)	1 to 7 days	
Extreme dirt	Dry	Light to medium	Slow to medium	0°F (-18°C)	200°F (93°C)	Daily flushing out dirt	
	High humidity Direct water Splash	Light to heavy	Slow to medium	32°F (0°C)	200°F (93°C)	1 to 4 weeks grease at shutdowns	Lithium or other corrosion control grease
		Heavy to very heavy	Slow	0°F (-18°C)	200°F (93°C)	1 to 8 weeks	High viscosity lubrication
				-20°F (-29°C)	120°F (49°C)	1 to 8 weeks	
		Light	High speed	100°F (38°C)	200°F (93°C)	1 to 8 weeks	Channeling (high speed) type grease
	Possible frost	Light to heavy	Slow to medium	-65°F (-54°C)	+250°F (121°C)	1 to 4 weeks grease at shutdown	Wide temperature range Diester-type greases (Silicone-Diester-Polyester lubricants)
Clean to moderate	Dry	Light to medium	Slow to medium	80°F (27°C)	250°F (121°C)	1 to 8 weeks	Good quality high temperature type greases
Clean to dirty	Dry	Light	Slow	80°F (27°C)	300°F (149°C)	1 to 4 weeks	Synthetic type greases

**Suggested starting interval for maintenance program. Check grease conditions for oiliness and dirt and adjust greasing frequency accordingly. Watch operating temperatures as sudden rises may show need for grease or indicate over lubrication on higher speed applications.

**维修计划建议的开始时间间隔。检查润滑脂油质污垢条件和条件并相应调整润滑频率。发现运行温度突然上升表明可能需要润滑或高速运行时润滑脂过多有溢出。

TABLE II 表二
RECOMMENDED GREASES
推荐润滑油脂

Use NLGI Grade 2 grease 使用 NLGI 2 级润滑油脂

Such As:

COMPANY 品牌	GREASE 润滑油脂
Chevron	SRI
CITGO	Premium Lithium EP2
Exxon	Lidok EP2
Keystone	81EP2
Pennzoil	PennLith 712
Shell	Alvania EP2
Texaco	Multifak EP2

WARNING!!! Use of lubricants other than those listed or their equivalent will cause reduced pump performance and reduce bearing life.

警告!!! 使用列表以外的润滑油脂或其它类同油脂将会导致泵性能降低和减少轴承使用寿命。

TABLE III 表三
RECOMMENDED OILS 推荐润滑油

	SPEED RANGE (RPM) 速度范围	
	1800 and Over	1500 and Below
	VISCOSITY RANGE 粘性范围	
MANUFACTURER 制造商	145 SSU TO 175 SSU @100°	270 SSU TO 375 SSU @100°
MOBILE OIL COMPANY	MOBILE DTE 797	DTE OIL HEAVY MEDIUM
SHEEL OIL COMPANY	TELLUS 927	TELLUS 933
TEXACO, INC.	REGAL A (R & O)	REGAL PC (R & O)
STANDARD OIL COMPANY	CHEVRON OC TURBINE 9	CHEVRON OC TURBINE 15
HUMBLE OIL & REFINING COMPANY	TERESSTIC OR TERESSO 43	TERESSTIC OR TERESSO 52
GULF OIL CORPORATION	HARMONY 44	HARMONY 53
UNION OIL OF CALIFORNIA	RED LINE TURBINE 150	RED LINE TURBINE 300
RICHFIELD DIVISION	EAGLE R & O NO. 10	EAGLE R & O LIGHT
ATLANTIC DIVISION ATL. RICH.	HYTHERM C	HYTHERM F
AMERICAN OIL COMPANY	AMER INDUSTRIAL OIL NO. 15	AMER INDUSTRIAL OIL NO. 31
CITIES SERVICE OIL COMPANY	CITGO PACEMAKER T-15	CITGO PACEMAKER T-30
CONTINENTAL OIL COMPANY	CONOCO DECTOL NO. 15 R & O	
E.F. HOUGHTON & COMPANY	HYDRO-DRIVE MIH LIGHT	HYDRO-DRIVE MIH-20
KEYSTONE LUBRICATING COMPANY	KLC-6	KLC-4A
PENNZOIL COMPANY	PENNBELL NO. 1	PENNBELL NO. 3
PHILLIPS PETROLEUM COMPANY	MAGNUS OIL 150	
PURE OIL COMPANY		PUROPALE RX HEAVY MEDIUM
SINCLAIR REFINING COMPANY	DURO 150	DURO 300
SUN OIL COMPANY	SUNVIS 916	SUNVIS 931

WARNING!!! Use of lubricants other than those listed or their equivalent will cause reduced pump performance and reduce bearing life.

警告!!! 使用列表以外的润滑油品或其它类同油品将会导致泵性能降低和减少轴承寿命。

SECTION VI 第六部分 REPAIRS AND REPLACEMENT 泵维修和配件更换

WARNING!!! Whenever any disassembly work is to be done on the pump, disconnect the power source to the driver to eliminate any possibility of starting unit.

警告!!! 任何时候需要对泵进行维修时, 必须先确保驱动机电源断开, 避免任何驱动机意外运行的可能。

6-1 To Remove Rotor: 拆卸泵壳

Reference: Pump Assembly Section

参考: 泵装配部分

1. Remove the coupling guard and disconnect coupling halves.
拆卸联轴器罩并断开联轴器连接件。
2. Disconnect any piping from the upper half casing (1B) that will interfere with its removal.
断开泵壳上半部分(1B)上所有连接影响拆卸的管路。
3. Remove bolting from the casing flanges and the bearing caps (41). **NOTE:** Some units are not provided with bearing caps. Remove bolting from the bearing bracket (31 & 33) and the lower case (1A).
卸掉泵壳连接用的螺栓以及轴承盖。注意: 有些泵型无轴承盖。卸掉轴承座(31、33)和泵壳下半部分(1A)连接的螺栓。
4. Drain oil from the reservoirs (oil lubricated ball bearing units only).
排空注油桶(仅适用于油润滑轴承泵型)内的润滑油。
5. Remove bolting through oil reservoirs (oil lubricated ball bearing units only). **NOTE:** On some units the oil reservoir is independent of the bearing housing. Remove the outboard oil reservoir with bolting (check Assembly Section).
卸掉注油桶连接螺栓(仅适用于油润滑轴承泵型)。注意: 部分泵型注油桶不与轴承座连接。拆除外侧集油槽(参阅装配部分)。
6. Screw jackscrews down to separate upper and lower case. Turn jackscrews back after separation to prevent interference at reassembly.
拆除泵吊耳螺栓。泵吊耳螺栓拧回后注意不影响上下泵壳安装。
7. Lift upper casing (1B) straight up until clear of the impeller.
将上部泵壳(1B)吊开, 即可看到叶轮。
8. Remove the bearing caps (41).
拆除轴承盖(41)。
9. Remove the glands (17) and the gland bolts (170).
拆除填料压盖(17)和压盖螺栓(170)。
10. Place slings around the shaft near the bearing housings and lift rotating element from lower casing (1A).
将吊索放在泵轴靠近轴承室位置, 将泵旋转组件从下部泵壳吊出(1A)。

11. Place rotating element in a clean, dry work area for necessary disassembly. Case wear rings (7) will be loose on assembly.
将拆卸下的旋转组件放在干净、干燥工作区域以便后续拆解。泵壳承磨环(7)装配时会松动。

6-2 Disassembly of Rotating Element: 泵旋转组件的拆卸

If the bearing assemblies do not require attention, but just the impeller or rings, then work just one side of the unit (impeller may be removed from either end).

如果不需要拆除轴承组件，只需要拆卸叶轮或磨损环，那么只需从旋转体的（组件）一侧进行拆卸(叶轮可以从旋转组件体任一端拆卸下来)。

1. Remove the pump half coupling.
拆卸泵联轴器连接件。
2. Loosen setscrews in deflectors (40) and slide toward center of the pump.
松开挡水板(40)的固定顶丝，并将其滑至泵的中部。
3. Remove cap screws from the bearing covers (35 & 37) and separate covers from the bearing housings (31 & 33).
卸开轴承盖(35&37)的固定螺丝，将轴承盖从轴承室上拿开(31&33)。
4. Remove bearing housings (31 & 33).
卸开轴承室(31&33)。
5. Straighten locking tip on lockwashers (69) and remove locknuts (22) and washers.
弯直后取出在锁紧螺圈(69)上的锁定卡销和移出锁紧螺母(22)和垫圈。
6. Remove oil flings (172) and oil rings (60) – (oil lubricated ball bearings only).
拆除抛油环(172)和油环(60)-(只适用油润滑轴承)。
7. Remove bearings (16 & 18). Remove with bearing puller pressing on the inside race. **Never** pull a bearing on the outside race unless the bearing is to be discarded.
拆除轴承(16&18)。用轴承拆卸器（拉马）从轴承内圈压或拉出。除非该轴承不再使用，也可从轴承外圈以支撑拉出。

NOTE: Items 8-10 refer to the sleeve bearing units only.

注意:下面的 8 - 10 项目只针对带轴承套泵型。

8. Remove thrust bearing cartridge (74), if applicable.
如果可以，拆卸轴承套件(74)。
9. Remove oil rings (60).
拆卸油环(60)。
10. Remove bolting from sleeve bearing halves (135 & 137) and remove bearings.
将轴承套(135 & 137)三大螺栓拆除，并拆除轴承。
11. Remove bearing covers (35) and deflectors (40).

拆除轴承盖(35)和导向挡板(40)。

12. Remove packing (13), lantern ring (29), and stuffing box bushing (63), if applicable. Note the number of packing rings on either side of the lantern ring. The lantern ring (29) must be installed opposite seal water inlet. **NOTE:** Follow the seal manufacturer's instructions for repair and removal of mechanical seals.
如果可以, 拆除填料(13), 水封环(29), 填料函衬套环(63)。注意水封环两侧填料环的数量。水封环(29)必须安装在密封进水管口对应的位置。注意: 按照密封制造商的说明进行维修和拆卸机械密封。
13. Loosen setscrews in sleeve nut (20) and unscrew the nut from the shaft.
在轴承套环螺母(20)松开固定螺丝并从轴上松开螺母。
14. Remove o-ring packing (13A) and shaft sleeves (14).
拆卸O形环包装(13)和轴套(14)。
15. Remove casing wear rings (7). On most pumps, casing rings may be removed before disassembling rotating element.
拆卸泵壳磨损环(7)。在大多数泵中, 泵壳承磨环可以在拆卸旋转组件之前拆卸。
16. Impeller (2) with impeller rings (8) can now be removed from either end of the shaft.
现在可以从轴的两端拆卸叶轮(2)与叶轮环(8)。

CAUTION: When removing the impeller, note the direction of the vanes. The impeller must be installed with the vanes in the same direction.

注意: 当拆卸叶轮时, 注意叶片的方向。叶轮安装时需保证叶片方向与其一致。

6-3 To Remove Impeller Rings: 拆卸叶轮承磨环

It is not necessary to remove the impeller from the shaft to replace the impeller rings. First remove the rotating element. Remove the locking set screws from the rings. The rings may now be pulled from the impeller, cut off with a chisel, or turned off, if a suitable lathe is available, using original shaft centers. **DO NOT CUT INTO THE BODY OF THE IMPELLER!** When new rings are installed, drill and tap new holes for the locking set screws – do not attempt to use old half holes in the impeller hub.

当替换叶轮承磨环时不需要拆卸轴上的叶轮。首先拆除旋转组件, 并拆卸环上的锁紧螺钉。这时从叶轮上卸下叶轮承磨环可能比较困难, 可以使用凿子凿断或者上车床完全将其车掉。注意不要切到叶轮本体! 当新的叶轮承磨环安装好, 为锁紧螺丝重新在叶轮上攻丝新的孔, 不要使用原来叶轮上的孔。

6-4 Inspection: 检查

Visually inspect parts for damage affecting serviceability. Check o-rings and gaskets for cracks, nicks, or tears; packing rings for excessive compression, fraying or shredding, and embedded particles. Replace if defective in any way. Mount the shaft between lathe centers and check eccentricity throughout the entire length. Eccentricity should not exceed .002 inches. Bearing surfaces should be smooth and shoulders square and free of nicks.

检查各部件的损伤程度是否影响其正常的使用。检查O形环和垫圈是否有裂痕, 裂纹或开口。检查填料密封是否过度被压缩, 磨损, 撕裂或嵌入异物。所检查的部件, 如果有任何缺陷就需要立即更换。检查泵轴整个长度范围内是否有偏心, 偏心不应超过 0.002 英寸。轴承表面应光滑, 轴肩垂直无裂痕。

Measure OD of impeller hub or impeller wear rings and ID of casing wear ring. Compute diametral clearance (ID minus OD) and compare with clearance given under the **Pump Specifications**.

测量叶轮轮毂或叶轮承磨环外径和泵壳承磨环的内径。计算径向间隙(ID - OD)然后与泵技术文件中给出的间隙比较。

Surfaces must be smooth and concentric. Examine impeller passages for cracks, dents or embedded material. Examine shaft sleeves for wear.

叶轮表面必须光滑、同心。检查叶轮内外是否有裂缝、凹陷或是否有异物。检查轴套是否磨损。

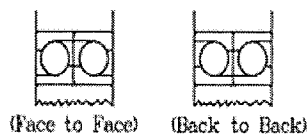

USING AN ARBOR PRESS

1. PLACE THE BEARING ON TWO FLAT BLOCKS SO THAT THEY CONTACT THE INNER RING OR BOTH RINGS OF THE BEARING.
2. HOLD SHAFT STRAIGHT, FORCE THE SHAFT BY A STEADY PRESSURE, UNTIL THE BEARING IS SEATED AGAINST THE SHAFT SHOULDER.

使用顶锤

1. 将轴承放置在装配平台上,以便平台和 轴承内圈 或内外圈相接触。
2. 将轴竖直, 给轴加一个稳定的压力,直到轴承和轴肩并齐。

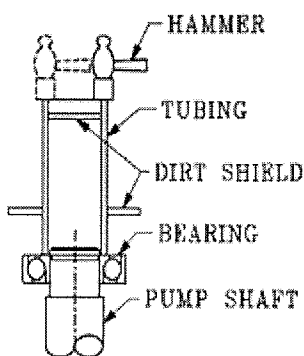
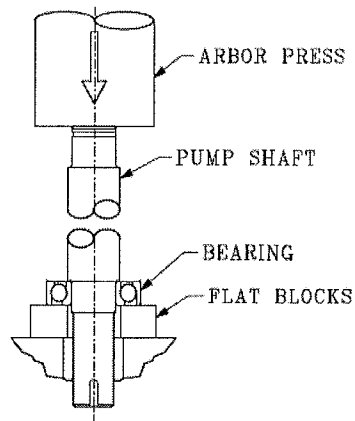

USING TUBING

1. PLACE THE BEARING ON SHAFT.
2. PLACE TUBING OVER SHAFT IN CONTACT WITH THE INNER RING OF THE BEARING.
3. APPLY HAMMER ALTERNATELY AT OPPOSITE POINTS AVOID COCKING.

使用套管

1. 将轴承装到轴上。
2. 将套管放到轴上与轴承内圈相接触。
3. 两个方向锤子交互击打, 避免错位倾斜。

USING A BEARING PULLER

1. PLACE BEARING PULLER BEHIND BEARING INNER RING. SET PULLER JAWS SO THAT THEY WILL NOT SLIP OVER THE INNER RING AND DAMAGE SEPARATOR OR SHILD WHEN PRESSURE IS APPLIED
2. FORCE BEARING OFF SHAFT BY A STRAIGHT PULL. DO NOT COCK BEARINGS.

使用轴承拉马

1. 将轴承拆卸器放到轴承内圈上。
2. 用直拉将轴承从轴上取出。不要旋塞轴承。

USING AN ARBOR PRESS

1. REST THE BEARING INNER RING OR BOTH RINGS (NEVER THE OUTER RING ONLY) AGAINST A PAIR OF FLAT BLOCKS.
2. FORCE THE SHAFT OUT BY A STEADY PRESSURE, KEEP SHAFT STRAIGHT. DO NOT ALLOW TO COCK OR DROP

使用顶锤

1. 轴承内圈或内外圈(不许只有外圈)顶在装配平台上。
2. 保持轴垂直, 用一个稳定的压力将轴取出。不允许旋塞或下压。

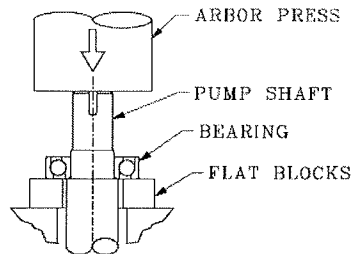
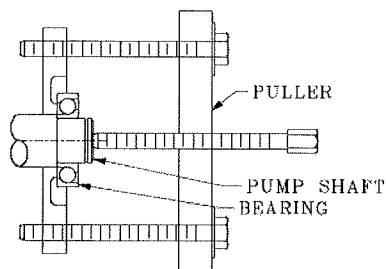

TABLE IV 表四

BEARING DEFECTS 轴承缺陷

(Failures – Replace if found)(失效—如果发现需更换)

DEFECT 缺陷(failure)	APPEARANCE 现象	PROBABLE CAUSE 可能的原因
Flaking and cracking 破损和开裂	In the early stages the surface of the inner and outer races develop small cracks, which flake. The cracks and flaking ultimately spread over the entire race surface. 早期, 在内圈外圈表面出现小裂缝破损。破损和剥落最终延伸到整个环的表面。	1. Normal fatigue failure. 正常的疲劳失效。 2. Bearing loads in excess of bearing capacity caused by misalignment. 错位造成的轴承负荷超过承载力。
Indentations 缺口	Indentations or cavities in the inner and outer races. 在内圈和外圈出现压痕或空腔。	1. Dirt in the bearings. 轴承中有污垢。 2. Excessive impact loading of the bearings such as improper mounting or removal. 如安装或拆卸不当造成对轴承过度的冲击荷载。
Broken separator (cage) 挡圈(笼)破损	Cracked separator or separator in pieces. 挡圈破裂或破碎。	1. Poor lubrication. 润滑失效 2. Misalignment of shaft. 轴错位 3. Excessive shaft deflection. 轴偏转过度
Wear 磨损	Bore and OD of outer ring of bearing galled or braided. 孔和轴承外圈外径擦伤。	1. Fit on shaft or in housing too loose. 轴上的空间太宽松。 2. Bearing locked by dirt and turning on shaft or in housing. 轴承被污垢和转动的轴或空间锁死。
Fractured ring 环损坏	Hairline cracks or complete ring fracture. 环出现细裂缝或完全断裂。	1. Forcing a cocked bearing on or off a shaft. 装上或卸下轴时用力过大。 2. Too heavy a press fit. 配合时压力过大。
Discoloration 污点	Balls and races darker than normal appearances of bearing metal. (Moderate discoloration of balls and races not a reason for discard). 轴承滚珠和轴承圈的颜色比正常的轴承合金颜色深。(适度的变色不是丢弃的理由)。	1. Inadequate lubrication. 润滑不充分。
Corrosion 腐蚀	Balls and raceways rusted. 滚珠和滑道生锈。	1. Water entering the housing. 水进入轴承室。 2. Condensation inside the housing. 轴承室中有凝结。 3. Lubricant breaks down into acid (wrong lubricant). 润滑剂分解成酸(错误的润滑剂)。

6-5 Assembly: 组装

Assembly is the reverse of the disassembly procedure. The following should prove helpful in reassembling the pump:

装配是拆卸步骤的反操作。以下在重新组装泵时是有用的:

1. All parts, inside and out, should be clean. Dirt and grit will cause excessive wear, plus needless shutdown.
所有零件内部外部应是干净的。污垢带入随部件装入将导致泵过度磨损, 以及不必要的故障。
2. Make certain that the keys are in their proper position.
确保定位销键在正确的位置。
3. Reinstall impeller with vanes in the right direction. Pump rotation is defined by viewing from the driver end. Impeller vanes slope must be opposite the pump rotation.
确保叶轮安装时与叶片方向上一致。泵旋转方向的定义是从驱动机端看的方向。叶轮叶片坡度一定要和泵旋转方向相对。
4. Do not lock sleeve nut (20) to the shaft until the impeller has been positioned in the center of the volute. This may be accomplished by loosening or tightening sleeve nuts against sleeves (14) as required, thereby working the impeller into position.
在叶轮被定位在泵壳的中心之前, 不要拧紧轴套上的锁紧螺丝(20)。通过调节锁紧螺丝使轴套(14)将叶轮定位并安装于正确位置。
5. Make certain that the case rings (7) are in proper position. The half-raised ring should be on the outside and completely in the lower half casing (1A). Be sure the ring is fully seated.
确保泵体承磨环(7)定位在正确的位置。这个环应该一半在外面, 另一半完全就位安装于泵的下半体(1A)。要确保承磨环完全安装好。
6. Insure that the packing does not block seal water inlet.
确保填料不会堵住密封冲洗冷却水入口。
7. Rotate by hand to insure that the parts do not bind before replacing upper half-case (1B).
安装泵上半部体(1B)前, 用手旋转部件, 以保证各个零部件工作正常, 无任何旋转阻碍。
8. Bearing mounting is simplified by heating the whole bearing, thereby expanding it enough to be slipped on the shaft. This heating is best done by submerging the bearing in a bath consisting of 10 - 15% soluble oil in water and heated to boiling. This mixture cannot be overheated, is non-flammable, drains off easily permitting convenient handling, and yet leaves an oil film sufficient for rust protection of the bearing surfaces.
将轴承加热后再安装就位于泵轴上是比较简单的方法。将轴承淹没在含 10 - 15%可溶性油的水中并加热到沸腾。这种加热导体不能过热, 是不易燃的, 方便处理, 而且会在轴承表面留下了足够的油膜防锈。

LOCATING OPERATING DIFFICULTIES 操作难点

In the majority of cases, operating difficulties are external to the pump and the following causes should be carefully investigated before undertaking repairs:

在大多数情况下，故障点是在泵的外部，应该仔细检查下列情况之后才能进行泵的维修：

No Water Delivered 没水

- Pump not primed – indicated by no pressure on discharge.
泵运行前未被灌满水—泵出口无压力。
- Speed too low – indicated by low pressure on discharge.
泵转速过低—泵出口压力低。
- Valve closed – indicated by high discharge head.
阀门关闭—泵出口压力过高。
- Impeller completely plugged up – indicated by low discharge pressure.
叶轮完全堵塞—泵出口压力低。

Abnormally Small Quantities Delivered 少数异常现象

- Air leaks in suction pipe or stuffing boxes.
在入口管路或填料函中有空气漏入。
- Speed too low.
泵转速过低
- Discharge head higher than anticipated.
出口压力高于预期。
- Impeller partially plugged up.
叶轮部分堵塞。
- Obstruction in suction line.
泵入口管路阻塞。
- Mechanical defects: casing rings worn, impeller damaged, casing or seal defective.
机械缺陷：泵体承磨环磨损，叶轮损坏，泵体或密封有破损。

Insufficient Pressure 压力不足

- Speed too low. Might be caused by low voltage or current characteristics different from nameplate reading on the motor.
泵转速太低。可能是由于电压过低，或者供电电源标准与电机的铭牌要求不同。
- Air in water will cause the pump to make a cracking noise.
水中含有空气会导致泵发出较大的噪音。

- Mechanical defects: worn casing rings, damaged impeller, defective casing or seal.
机械缺陷：泵体环磨损、损坏叶轮、泵体或密封破坏。

Intermittent Operation 泵运行性能不稳定

- Leaky suction line.
泵入口管路有渗漏（或者带入空气的可能）
- Water seal plugged (hence, a leaky stuffing box).
密封冲洗冷却水管堵塞(因此填料函会漏水)。
- Suction lift too high.
泵吸程太高。
- Air, gas or vapor in liquid.
泵流体（介质）中含有空气，气体或水蒸气。

Pump Overloads Driver 泵使驱动机过载运行

- Speed too high.
泵转速过高。
- Head lower than rated, hence, pumping too much water. (This is valid for low specific speed pumps).
泵出口压力低于额定值，泵过流量太大。(这对于低速泵是有效的)。
- Mechanical defects: stuffing boxes too tight, shaft bent, rotating element binds.
机械缺陷：填料函太紧，轴弯曲、旋转部件旋转不畅。
- Rubbing due to foreign matter in the pump between the case rings and the impeller.
泵体承磨环和叶轮之间有异物摩擦。

Pump Vibrates 泵的震动

- Misalignment.
未对中
- Foundation not sufficiently rigid.
基础没有足够的刚性。
- Impeller partially clogged.
叶轮部分堵塞。
- Mechanical defects: bent shaft, rotating element binds, bearings worn, coupling defective.
机械缺陷：轴弯曲，旋转部件旋转不畅，轴承磨损，联轴器有缺陷的。
- Suction and discharge pipes not anchored.
泵入口出口管道没有稳固安装。

- Pump cavitating from too high a suction lift.
由于泵吸程太高，气蚀原因。
- Air entrainment in the pump suction due to low submergence.
由于泵入口管路浸没于水池太浅，大量空气随如水口一并进入泵。

RECOMMENDED SPARE PARTS FOR DOUBLE SUCTION PUMPS 双吸泵推荐的备件

Reference: Assembly Section

参考: 组装部分

INTERMITTENT DUTY 间歇运行工况

Number 编号	Description 描述
7	Casing Ring 泵体承磨环
8	* Impeller Ring 叶轮承磨环
13	* Packing (stuffing box) 填料(填料函)
13A	Packing O-Ring (shaft sleeve) 填料 O 型圈(轴套)
14	* Shaft Sleeve 轴套
65	+* Mechanical Seal (stationary element) 机械密封(固定部件)
80	+* Mechanical Seal (rotating element) 机械密封(旋转部件)
	Coupling and its accessories (not shown) 联轴器及其配件(未显示)
	Gasket (not shown) 垫片(未显示)
	Gland Bolts (not shown) 填料压盖螺栓(未显示)

CONTINUOUS DUTY 连续运行工况

Number 编号	Description 描述
2	Impeller 叶轮
6	* Shaft 轴
7	Casing Ring 泵体承磨环
8	* Impeller Ring 叶轮承磨环
13	* Packing (stuffing box) 填料(填料函)
13A	Packing O-Ring (shaft sleeve) 填料 o 型圈(轴套)
14	* Shaft Sleeve 轴套
16	Bearing (inboard) 轴承(内侧)
18	Bearing (outboard) 轴承(外侧)
20	Shaft Sleeve Nut 轴套螺母
20A	* Impeller Locknut 叶轮锁定螺母
22	Bearing Locknut 轴承锁定螺母
32	Impeller Key 叶轮定位键
40	Deflector 导向板
46	Coupling Key 联轴器定位键
65	+* Mechanical Seal – Stationary Element 机械密封—固定部件
68	Shaft Collar 轴肩挡圈
80	+* Mechanical Seal – Rotating Element 机械密封—旋转部件
	Coupling and its accessories (not shown) 联轴器及其配件(未显示)
	All Hardware (not shown) 所有的五金件(未显示)
	Gasket (not shown) 垫片(未显示)
	Gland Bolts (not shown) 压盖螺栓(未显示)

* Determined by Pump Construction 由泵结构决定

+ Complete Consists of 65 & 80 包括完整的 65 & 80

ITEM	DESCRIPTION
1A	LOWER CASING
1B	UPPER CASING
2	IMPELLER
6	SHAFT
7	CASING RING
8	IMPELLER RING (OPTIONAL)
13	PACKING
13A	O-RING
14	SHAFT SLEEVE
16	INBOARD BEARING (RADIAL)
17	PACKING GLAND
18	OUTBOARD BEARING (THRUST)
20	SLEEVE NUT
29	LANTERN RING
31	INBOARD BEARING HOUSING
32	IMPELLER KEY
33	OUTBOARD BEARING HOUSING
35	INBOARD BEARING COVER
40	INNER DEFLECTOR
41	INBOARD BEARING CAP
41A	OUTBOARD BEARING CAP
46	COUPLING KEY
63	STUFFING BOX BUSHING
123	END CAP
125	GREASE FITTING
127	SEA WATER PIPING
171	BEARING RETAINING RING
172	BEARING END COVER RETAINING RING

